



19772 Pauling • Foothill Ranch, CA 92610-2611 USA
TEL: (949) 465-3000 • FAX: (949) 465-3020
www.imcnetworks.com

iMediaChassis/3

Operation Manual

**ISO 9001:2000
REGISTERED**



© 2007 IMC Networks. All rights reserved.

The information in this document is subject to change without notice. IMC Networks assumes no responsibility for any errors that may appear in this document. iMediaChassis/3 is a trademark of IMC Networks. Other brands or product names may be trademarks and are the property of their respective companies.

Document Number 50-80949-01 A0

August 2007

If the product's part number begins with an "8", it is compliant with the Restriction of Hazardous Substances (RoHS) directive.



FCC Radio Frequency Interference Statement

This equipment has been tested and found to comply with the limits for a Class B computing device, pursuant to Part 15 of the FCC Rules. These limits are designed to provide reasonable protection against harmful interference when the equipment is operated in a commercial environment. This equipment generates, uses and can radiate radio frequency energy and, if not installed and used in accordance with the instruction manual, may cause harmful interference to radio communications. Operation of this equipment in a residential area is likely to cause harmful interference in which the user will be required to correct the interference at his own expense.

Any changes or modifications not expressly approved by the manufacturer could void the user's authority to operate the equipment.

The use of non-shielded I/O cables may not guarantee compliance with FCC RFI limits. This digital apparatus does not exceed the Class B limits for radio noise emission from digital apparatus set out in the Radio Interference Regulation of the Canadian Department of Communications.

Le présent appareil numérique n'émet pas de bruits radioélectriques dépassant les limites applicables aux appareils numériques de classe B prescrites dans le Règlement sur le brouillage radioélectrique publié par le ministère des Communications du Canada.

Warranty

IMC Networks warrants to the original end-user purchaser that this product, EXCLUSIVE OF SOFTWARE, shall be free from defects in materials and workmanship under normal and proper use in accordance with IMC Networks' instructions and directions for a period of six (6) years after the original date of purchase. This warranty is subject to the limitations set forth below.

At its option, IMC Networks will repair or replace at no charge the product which proves to be defective within such warranty period. This limited warranty shall not apply if the IMC Networks product has been damaged by unreasonable use, accident, negligence, service or modification by anyone other than an authorized IMC Networks Service Technician or by any other causes unrelated to defective materials or workmanship. Any replaced or repaired products or parts carry a ninety (90) day warranty or the remainder of the initial warranty period, whichever is longer.

To receive in-warranty service, the defective product must be received at IMC Networks no later than the end of the warranty period. The product must be accompanied by proof of purchase, satisfactory to IMC Networks, denoting product serial number and purchase date, a written description of the defect and a Return Merchandise Authorization (RMA) number issued by IMC Networks. No products will be accepted by IMC Networks which do not have an RMA number. For an RMA number, contact IMC Networks at PHONE: (800) 624-1070 (in the U.S and Canada) or (949) 465-3000 or FAX: (949) 465-3020. The end-user shall return the defective product to IMC Networks, freight, customs and handling charges prepaid. End-user agrees to accept all liability for loss of or damages to the returned product during shipment. IMC Networks shall repair or replace the returned product, at its option, and return the repaired or new product to the end-user, freight prepaid, via method to be determined by IMC Networks. IMC Networks shall not be liable for any costs of procurement of substitute goods, loss of profits, or any incidental, consequential, and/or special damages of any kind resulting from a breach of any applicable express or implied warranty, breach of any obligation arising from breach of warranty, or otherwise with respect to the manufacture and sale of any IMC Networks product, whether or not IMC Networks has been advised of the possibility of such loss or damage.

EXCEPT FOR THE EXPRESS WARRANTY SET FORTH ABOVE, IMC NETWORKS MAKES NO OTHER WARRANTIES, WHETHER EXPRESS OR IMPLIED, WITH RESPECT TO THIS IMC NETWORKS PRODUCT, INCLUDING WITHOUT LIMITATION ANY SOFTWARE ASSOCIATED OR INCLUDED. IMC NETWORKS SHALL DISREGARD AND NOT BE BOUND BY ANY REPRESENTATIONS OR WARRANTIES MADE BY ANY OTHER PERSON, INCLUDING EMPLOYEES, DISTRIBUTORS, RESELLERS OR DEALERS OF IMC NETWORKS, WHICH ARE

INCONSISTENT WITH THE WARRANTY SET FORTH ABOVE. ALL IMPLIED WARRANTIES INCLUDING THOSE OF MERCHANTABILITY AND FITNESS FOR A PARTICULAR PURPOSE ARE HEREBY LIMITED TO THE DURATION OF THE EXPRESS WARRANTY STATED ABOVE.

Every reasonable effort has been made to ensure that IMC Networks product manuals and promotional materials accurately describe IMC Networks product specifications and capabilities at the time of publication. However, because of ongoing improvements and updating of IMC Networks products, IMC Networks cannot guarantee the accuracy of printed materials after the date of publication and disclaims liability for changes, errors or omissions.

Notes

FCC Radio Frequency Interference Statement	ii
Warranty.....	ii
About the iMediaChassis/3	1
Installing the iMediaChassis/3.....	2
Installing Application Modules.....	2
Installing Management Modules.....	3
Connecting Chassis and Modules	4
Configuring an SNMP-Management Card.....	4
SNMP Write Lock	4
Using Telnet.....	6
About DHCP.....	6
About iConfig.....	7
About Serial Port Configuration	7
Before using iView ²	12
Installing and Using iView ²	12
Power Supply.....	13
Temperature Control.....	14
Specifications.....	15
IMC Networks Technical Support.....	16
Safety Certifications.....	16

Telephone: (949) 465-3000
Toll Free: (800) 624-1070 (U.S.A. and Canada)
Europe: + 32-16-550880
FAX: (949) 465-3020
E-Mail: techsupport@imcnetworks.com
Web Site: www.imcnetworks.com

Safety Certifications

UL/CUL: Listed to Safety of Information Technology Equipment, including Electrical Business Equipment.

CE: The products described herein comply with the Council Directive on Electromagnetic Compatibility (89/336/EEC) and the Council Directive on Electrical Equipment Designed for use within Certain Voltage Limits (73/23/EEC). Certified to Safety of Information Technology Equipment, Including Electrical Business Equipment. For further details, contact IMC Networks.



European Directive 2002/96/EC (WEEE) requires that any equipment that bears this symbol on product or packaging must not be disposed of with unsorted municipal waste. This symbol indicates that the equipment should be disposed of separately from regular household waste. It is the consumer's responsibility to dispose of this and all equipment so marked through designated collection facilities appointed by government or local authorities. Following these steps through proper disposal and recycling will help prevent potential negative consequences to the environment and human health. For more detailed information about proper disposal, please contact local authorities, waste disposal services, or the point of purchase for this equipment.



About the iMediaChassis/3

The iMediaChassis/3 is a modular chassis platform designed for use with the IMC Networks SNMP-manageable series of modules (iMcV). The iMediaChassis/3 features three slots for installing application series modules plus an additional slot for installing an SNMP management module. The included SNMP Lock feature allows the management slot to save SNMP settings while the management module is removed.

The iMediaChassis/3 can also hold two double wide "iMcV" modules, when there is no SNMP management card in the management slot. Double-wide modules with built-in management, such as the iMcV-Giga-FiberLinX-II, can be managed in the chassis without the need for an SNMP module in the management slot.

The power supply configurations available for the iMediaChassis/3 include the following:

- Single AC
- Single DC
- AC and DC
- AC and AC
- DC and DC

This chassis is shipped with three of the slots covered by faceplates and one slot open (slot 3).

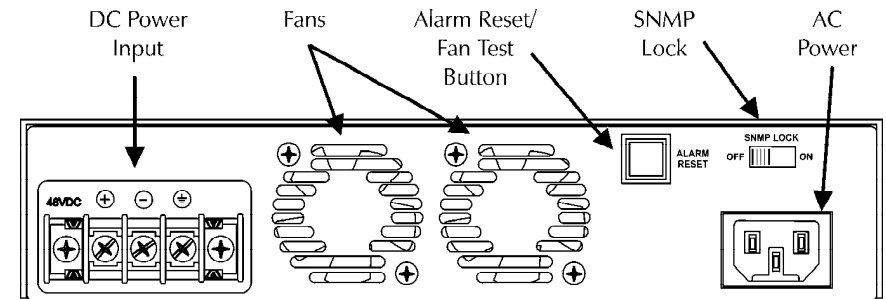

iMediaChassis/3 with AC & DC power supplies

Installing the iMediaChassis/3

Before installing the application modules into an iMediaChassis/3, install the chassis first. When installing the chassis, be sure to observe the following precautions to prevent electrical or mechanical damage:

- Stay within the chassis power rating to prevent overload of supply circuits or damage to overcurrent protection and supply wiring.
- Maintain reliable earth ground, especially when connecting to a power strip instead of directly to a branch circuit.
- Protect the chassis from exposure to sunlight and electrical or magnetic fields.

Fault-Tolerant Power

The fault-tolerant powering option applies to units utilizing two power supplies. If failure occurs on one power supply, the other supply takes over in its place and carries the power load. Refer to the *Power Supply* and *Temperature Control* sections for wiring, alarm, and Trap information.

NOTE

The iMediaChassis/3 power supply is not field replaceable.

Installing Application Modules

Refer to the module installation guide for configuration information. To install a module, remove the faceplate (if present) covering the slot where the module will be installed. Double-wide modules will occupy two slots. Slide the module into the chassis using the card guides, and secure the module to the chassis by tightening the captive screw. Each module slot provides 1.5 Amps. The management slot uses a connector that is longer than slots 1-3 and should only be used for installing the management module.

INSTALLATION TIP

The module hardware configuration that is set using DIP switches is overridden by the chassis management when the module is installed in a managed chassis.

Use the management software to ensure that the module is properly configured.

Specifications

DC Power Supply:

Input voltage: 35 to 75 VDC

Input Current: 2.7A maximum @35 VDC, Full Load

Output Current Capability (per supply): 15A @5VDC

AC Power Supply:

Input Voltage: 90 to 264 VAC, 47-440HZ

Inrush Current: < 60A Peak @230 VAC

Input Power: < 74W

Output Current Capability (per supply): 11A@5VDC

Operating Temperature:

32° to 122° F (0° to 50° C)

Storage Temperature:

0° to 160° F (-20° to 70° C)

Humidity:

5 to 90% (non-condensing); 0 to 10,000 ft. altitude

Heat Output:

171 BTUs

Shipping Weight:

5 lbs (2.3 kg)

Dimensions:

H= 1.73" W= 7.50" D= 8.74" (4.4 x 19.0 x 22.0 cm)

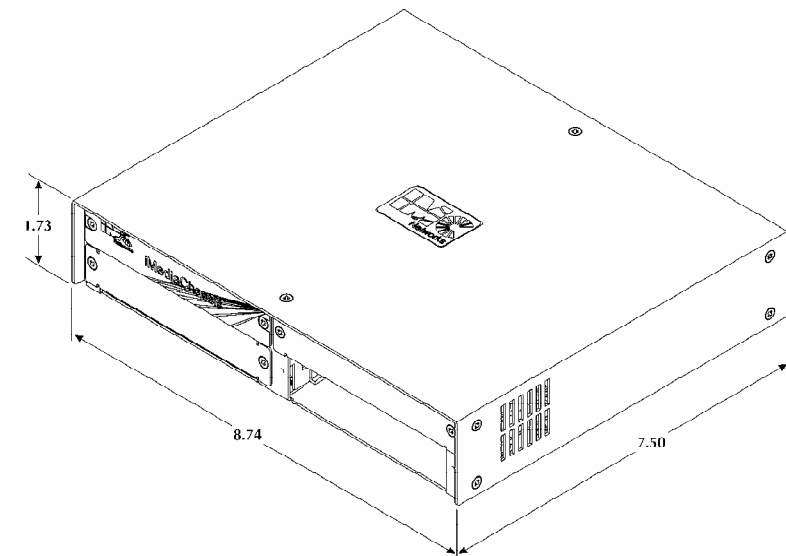

Alarm Reset

This feature is available on the fault-tolerant (dual-power supply) model of the iMediaChassis/3. When one power supply malfunctions, an alarm will sound. A red alarm reset button, located next to the power connector on the right side of the power supply, stops this alarm. The LEDs on the management module and the iView² software both display power supply failures. If a power supply failure occurs, return the iMediaChassis/3 to IMC Networks for repair or replacement.

Last Gasp Alarm

The iMediaChassis/3 includes the Last Gasp feature, which sends a Trap when the following occurs:

- Both power supplies malfunction,
- Both power supplies are powered down
- When the AC line fails

Temperature Control

The iMediaChassis/3 includes temperature activated fans and an SNMP temperature Trap to protect the chassis from overheating.

Temperature Triggered Fans

The iMediaChassis/3 includes temperature triggered fans. When the temperature of the chassis reaches 40° C, the two fans are activated. You can test the fans operation by holding the Alarm Reset button down for 4 to 5 seconds. The fans will activate and then they will turn off when you release the button. If the fans do not activate, contact IMC Networks.

Temperature SNMP Trap

The management module includes a heat sensor for monitoring the temperature of the iMediaChassis/3. You can define a threshold for chassis temperature by using SNMP (refer to the iView² online help for more information about assigning Traps). When the temperature of the chassis rises above the specified level, the SNMP agent sends a Trap to the administrator. There is also an LED indicator on the SNMP Management Module for module temperature (refer to the *SNMP Management Module LEDs* section for more information).

Installing Management Modules

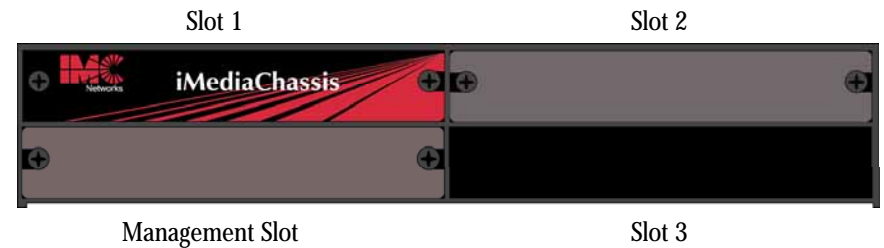

An SNMP Management Module must be installed in the iMediaChassis/3 to enable module and chassis management (except when using modules with built-in management, such as the iMcV-Giga-FiberLinX-II). The SNMP Management module installs in the management slot located at the bottom left of the chassis. This slot is only for the management module; do not install application modules such as media conversion and mode conversion modules in this slot. Double wide modules installed in Slot 1 will overlap the management slot.

NOTE

The SNMP Management module includes DIP switches. These switches are factory set and must not be moved.

SNMP Management Module LEDs

Each SNMP Management Module features several LEDs.

The LED functions are:

- **LNK/ACT**
Glow green when a link is established on port.
Blinks green when data activity occurs.
- **FDX/COL:**
Glow amber when port is in Full-Duplex mode.
Blinks amber when port is operating in Half-Duplex mode and collisions occur.
- **TEMP:**
Glow amber when temperature of unit surpasses a user-defined level.
- **PS**
Not used for the iMediaChassis/3.
- **FAN A / FAN B**
Not used for the iMediaChassis/3.



Connecting Chassis and Modules

An iMediaChassis/3 with an installed management module connects to the LAN via an external 10/100 twisted pair connection. Connect the chassis to the network by plugging one end of a CAT-5 twisted pair cable into the port labeled **MGMT** on the management card, or the management-enabled application card. Plug the other end of the cable into a device (e.g., switch, hub, etc.) in an existing Ethernet network. The port labeled **OPTION** is reserved for future use. Both twisted pair ports include the AutoCross feature. This feature automatically enables either a crossover or a straight-through connection, depending on the connected device.

Configuring an SNMP-Management Card

Once connected to the LAN, assign the iMediaChassis/3 IP configuration information (e.g., IP address, subnet mask, etc.).

You can assign the IP information by using one of the following:

- iConfig
- The management module serial port
- DHCP (Dynamic Host Control Protocol); DHCP must be enabled through serial configuration

You can also create community strings, assign access rights, configure Traps and more. Using iConfig allows more Trap and MIB access configuration options than when using the serial port.

After assigning the iMediaChassis/3 an IP address, use iView² or another SNMP-compatible Network Management System (NMS) to remotely configure, monitor and manage the modules installed within the unit.

SNMP Write Lock

There is an SNMP Write Lock switch located on the back of the iMediaChassis/3. The SNMP Write Lock switch prevents a new management board from re-configuring the application module settings (like the status of features such as LinkLoss, FiberAlert, Force mode, etc.) made by SNMP and held on the previous management board.



When Not Using iView²

When using an application other than iView² for management, integrate the SNMP vendor files (a.k.a. MIBs) into the application. The SNMP agent uses the following Enterprise-specific MIB file and standard MIBs, which can be found in the MIB directory on the CD included with the iMediaChassis/3: MCIMCV2C.MIB Enterprise-specific information for the agent. For example, configuration information, port type information, link status, etc.

Using the MCIMCV2C.MIB

Refer to the management software documentation for information on how MIB files are integrated into the software.

Power Supply

The iMediaChassis/3 ships with one or two AC or DC power supplies, or one of each, depending on the model.

DC Power Supply Wiring Instructions

The following image shows the wiring configuration for a Telco application of -48 VDC power supply for the iMediaChassis/3.

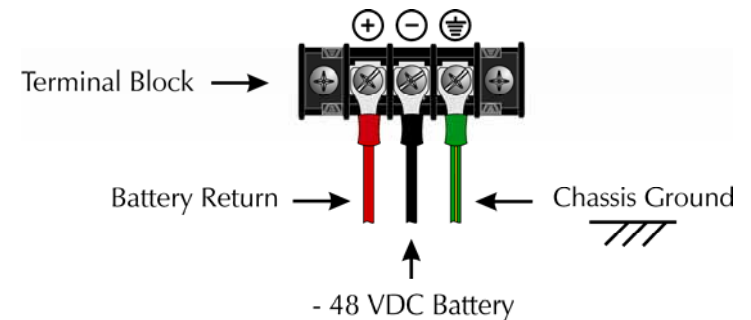

NOTE

Incorrect wiring will result in chassis malfunction. The iMediaChassis/3 is compliant with Isolated Grounding Plane practices. The POSITIVE and NEGATIVE terminals are isolated from chassis ground and must have a ground reference at the power-sourcing equipment.

iView² is a network management application designed for use on the IMC Networks intelligent networking devices. It features a graphic user interface (GUI) and gives network managers the ability to monitor and control products from a variety of platforms. iView² can also function as a snap-in module for HP OpenView Network Node Manager.

System Requirements

To run iView², the management PC must be equipped with the following:

- 29 MB free disk space, 64 MB RAM
- Windows: NT 4.0 Service Pack 5, 2000 Professional, or XP
- Microsoft SNMP Services Installed
- Microsoft IE 4.0 or Higher (not required as default browser)
- Microsoft IIS required for Web Server version

Java versions require the following:

- 25 MB free disk space, 64 MB RAM
- Any OS capable of running Java (Windows 98 or above, Solaris, LINUX)
- Java Runtime v 1.3

Strongly recommended:

- 128 MB RAM
- Pentium III 650Mhz or Faster
- 17" Monitor @ 1024 x 768 Resolution or higher

Installing and Using iView²

Please consult the iView² CD for installation information. The iView² help file provides assistance in configuring/managing IMC Networks' modules.

When Using iView² with HP OpenView

During the installation, the iView² application will ask if HP OpenView is installed on the management PC. Click **Yes** to integrate the appropriate files. Once in OpenView, select IMC Networks from the toolbar to view the IMC Networks devices.

The switch has two settings. **OFF** is the normal operating position and **ON** is the locked position.

IMPORTANT USAGE INFORMATION
<i>Leave the SNMP Write Lock switch in the OFF position during day-to-day operation. ONLY move the switch to the ON position when changing the SNMP management board.</i>

The SNMP management module can be removed and replaced when necessary. A saved firmware file can be uploaded to the second SNMP module to retain configuration settings. Make sure that the SNMP Write Lock switch is set to the **ON** position. Save the firmware file periodically in case there is a need to replace the SNMP management module (refer to the *About Serial Port Configuration* section for more information).

When the management module is removed while the SNMP Write Lock switch is set to **OFF**, the application module configurations revert to DIP switch settings. Make sure the DIP switches are set to the same configuration as the SNMP management. Re-installing the same management module will return the application modules to the SNMP management configuration. Installing a new management module when the switch is set to **OFF** will cause the installed application modules to use the management settings of the new module. Make sure to always reconfigure application modules when moving them from one chassis to another.

Using the SNMP Write Lock Switch

To lock the SNMP module settings by using the SNMP Lock Switch, perform the following:

1. Set the SNMP Write Lock switch to **OFF**.
2. After configuring all application module settings by using SNMP, use iConfig to make a backup copy of the SNMP management module firmware.

NOTE
<i>These first two steps are typically performed during initial installation.</i>

3. To replace the SNMP management module, first set the SNMP Write Lock switch to **ON**.
4. Remove the old SNMP management module and replace it with another SNMP module.
5. Access the SNMP management module using iConfig. Select the **Administration** tab and click on **List Tasks**. Highlight **Flashsav** and click the **Terminate** button.
6. Update the new board with the firmware backup made in step 2.

7. Reboot the SNMP management module with the **reboot** command to enable changes.
8. After rebooting, set the SNMP Write Lock switch back to **OFF**. The previously made settings are now active.

NOTE

*When an SNMP card is removed while the Write Lock switch is set to **ON**, the current application module settings are retained.*

*Never power-cycle the chassis while the Write Lock switch is set to **ON**. This will reset the SNMP card back to its original factory settings.*

*SNMP (iView²) communication with the chassis is disabled when the Write Lock switch is set to **ON**.*

Using Telnet

The iMediaChassis/3 supports Telnet for remote configuration. Assign the iMediaChassis/3 an IP address before using a Telnet session (refer to the *Assigning IP Information* section for more information). All of the configurations that are available from the serial port are also available from Telnet. Use only one Telnet session at a time. Do not use an RS-232 serial session and a Telnet session at the same time.

NOTE

A Telnet session uses the same password as the iConfig application.

About DHCP

There is a DHCP client in the SNMP Management Card. By default, the DHCP client is disabled. If a DHCP server is present on the network and DHCP is enabled, the DHCP client will initiate a dialogue with the server during the boot up sequence. The server will then issue an IP address to the management card. Once the new IP address is received, the iMediaChassis/3 will reboot so that the new IP address will take effect. Refer to the *About Serial Port Configuration* for more information about Enabling/Disabling DHCP. When there is no DHCP server on the network, use iConfig or serial configuration to manually set the IP addresses.

When DHCP is enabled, the IP address (default 10.10.10.10 or user configured) is saved. When DHCP is disabled, the saved IP address will be reinstated and the device will reboot.

DHCP servers give out lease times: devices renew their leases based on the administrator-specified time. If a device cannot renew its lease, and the lease expires, the device will be given the IP address 10.10.10.10 and will reboot.

Type the name of the action and press **Enter**.

- **tasks**
Displays the task list including the task priority.
- **memory**
Displays the memory usage.
- **cleandb**
Removes all information in the database except the IP address of device.
- **download**
Opens the firmware TFTP download screen.
- **version**
Displays the firmware version and build date.
- **reboot**
Reboots the unit.
- **accounts**
Allows management of Usernames/Passwords account. Administrators must maintain a password list.
- **modules**
Displays a list of installed modules including slot location.

Downloading Files

The iMediaChassis/3 accepts firmware downloads from a central server by using TFTP protocol. Use serial configuration or a Telnet session to perform this download. Make sure the IP Address and the name of the file are correct in the Current Values section of the Main Configuration screen. If this information is not correct, make the appropriate changes. To download a file, press the **Space Bar** from the Command List section of the Main Configuration screen (serial configuration). Type **download** and press **Enter** to display the Download a File screen. This screen displays the IP Address of the TFTP server and the name of the file. Press **Enter** to start downloading the file.

If the download is interrupted, do not reset the module or reboot the chassis. Close the session, then open a new TFTP session.

Assigning Trap Destinations

The manageable device sends Traps to a management PC when a certain event takes place. To enter a Trap destination, press **T**. Type the IP address of the destination device when asked to "Enter a New IP Address." Then, press **Enter**. Type the name of the community string (that the destination device has been configured to accept) and press **Enter**. This function enables all of the device's Traps. Use iConfig to selectively activate and de-activate specific Traps.

Removing Trap Destinations

To remove all Trap destinations, press **K**. Press **Y** to confirm. Press **N** to abort. Then, press **Enter**.

Password Protection on Serial Port

Password protect the serial configuration process by pressing **P** from the main configuration screen. Enter a password. (Passwords are case sensitive.) Enter the password (spaces are NOT allowed) and press **Enter**. This password will be requested whenever logging on. To remove password protection, select **P** and instead of entering a password press **Enter**.

It is the responsibility of the network administrator to store and maintain the password lists. If passwords are lost, neither the end user nor IMC Networks can retrieve them.

Enabling/Disabling DHCP

To Enable/Disable DHCP, press **D**. Then, type **reboot** for the changes to take effect.

Ending a Session

Be sure to press **E** before disconnecting the cable. This stops the device from sending feedback status through to the serial port.

Device-Specific Options

Pressing the space bar from the Main Configuration screen opens the Device Specific Commands screen:

Command	Description
tasks	Display Task List
memory	Display Memory Usage
cleandb	Reboot With Clean Database
download	File Download
version	Show Firmware Version
reboot	Reboot Unit
sysdescr	Change System Descriptions
accounts	Add or Delete Username/Password Accounts
modules	Display Modules

->
Press RETURN To Go Back To Main Screen.

About iConfig

iConfig is a configuration utility (part of iView²) that lets users quickly and easily complete the first stages of SNMP configuration for SNMP-manageable devices. iConfig can set the IP address, subnet mask and default gateway as well as define the SNMP community strings and Traps.

In addition to the above functions, iConfig offers an authorized IP address system and access restriction to MIB groups supported by manageable devices. These extra layers of security are purely optional and do not affect SNMP compatibility in any way.

The iConfig utility can also be used to upload new versions of the system software. It also offers diagnostic capabilities for faster resolution of technical support issues.

The default user ID for both iConfig and Telnet is:

- **User:** admin
- **Password:** admin

The iConfig utility works with the Windows 98, Windows NT, Windows 2000, and Windows XP operating systems.

The iConfig utility is available as a standalone application as well as built in to the Windows version of iView² (Windows 98 users must use the standalone version of the iConfig utility). Both applications are included on the iView² CD. Refer to the iConfig utility online help file for more information about the iConfig utility.

About Serial Port Configuration

The SNMP management module used with the iMediaChassis/3 features a serial port that includes an IBM-compatible DB-9 serial connector. To connect an iMediaChassis/3 to a computer, use a straight-through (pin-to-pin) cable. (When the computer has a serial port using a connection not compatible with a DB-9 COM port, use the pin connection chart for reference in making a cable.) Make sure the cable length is less than 50 ft. (15.24 m). Plug one end of the cable into the DB-9 connector on the iMediaChassis/3 and the other into the appropriate port on the computer.

DB-9 Pin Connection Chart	
Function	Pin#
Transmit (Out)	2
Receive (In)	3
Ground	5
Reserved	1,4,6-9

Set the computer for VT-100 emulation. The serial port on the computer should be set for: 38.4K baud, 8 data bits, 1 stop bit, no parity, no flow control.

Main Serial/Telnet Configuration Screen

After running through an initial self-test, the screen will display the following message: “< Press Enter> for Device Configuration.” Press **Enter** to display the main configuration screen:

```
Saved Values. <These values will be active after reboot>
IP Address      - 10.10.10.10
Subnet Mask     - 255.0.0.0           DHCP is not active
Default Gateway - 000.000.000.000
Server IP Addr  - 000.000.000.000
New Prom File   - filename

Current Values. <These values are in use now>
IP Address      - 10.10.10.10
Subnet Mask     - 255.0.0.0
Default Gateway - 000.000.000.000
Server IP Addr  - 000.000.000.000
New Prom File   - filename

Community String: public      Access: r/w

Press I to enter new saved parameter values. Press P to change Password.
Press T to enter new Trap Destination. Press K to remove ALL Trap Destinations.
Press C to enter new Community String. Press U to remove ALL Community Strings.
Press E to End session. Type REBOOT to reboot unit. Press D for DHCP On/Off.
Press SpaceBar for additional commands.
```

Saved Values — displays changes made during current session.

- IP Address (MUST be assigned during initial configuration)
- Subnet Mask (MUST be assigned during initial configuration)
- Default Gateway
- Server IP Address
- PROM File Name

Current Values — displays values currently in use.

- IP Address (IP address of SNMP agent)
- Subnet Mask (mask to define IP subnet to which agent is connected)
- Default Gateway (default router for IP traffic outside subnet)
- Server IP Address
- PROM File Name

Commands

- **I** = Enter New Saved Parameter Values
- **P** = Change Password
- **T** = New Trap Destination
- **K** = Remove ALL Trap Destinations
- **C** = New Community String
- **U** = Delete ALL Community Strings
- **D** = Enable/Disable DHCP
- **E** = End Session
- **Space Bar** = Opens device specific configuration options (tasks, memory, cleandb, download, version, reboot, sysname, accounts, and modules).

NOTE

The **F2** key functions as a Delete key on VT-100 terminal emulators. Reboot after making any modifications to the Saved Values or changes will not take effect. To reboot, type the word **reboot** at the prompt on the main configuration screen, or cycle the power. Never cycle the power with the SNMP Write Lock switch set to **ON**.

Assigning IP Information

To modify the Saved Parameter Values (i.e., assign IP address and subnet mask), press **I**. Enter the IP address and subnet mask for the connected device. Press **Enter** after each. A Default Gateway may also be assigned (or press **Enter** to skip).

When finished, press **Enter**, then type **reboot** for changes to take effect. The Saved Values and Current Values should now both display the changes made (e.g., new IP address and subnet mask).

Creating Community Strings for SNMP

The purpose of community strings is to add a level of security to a network. The default community string is named “public” and has read/write access. Delete the “public” string and add necessary custom community strings such as one with read-only access (for general use), the other with read/write access (for the administrator).

To create a new community string, go to the main configuration screen and press **C**. Enter the name of the new community (up to 16 characters, no spaces) and press **Enter**. Assign the community string’s access rights by typing one of the following:

- R = read-only access
- W = read/write access
- Enter = abort

Press **Enter** to create the Community String. When finished, press **Enter**, then type **reboot** for changes to take effect.

The Saved Values and Current Values should now both display the changes made (e.g., new IP address and subnet mask).

Deleting Community Strings

To delete all community strings and start over, press **U**. Press **Y** to proceed, **N** to abort when asked, “Are you sure you want to delete all future strings?” Then, press **Enter**.

This function will delete all community strings. Use iConfig to selectively delete community strings.